

# MULTITEL



## 160ARLU



- Commandes électro-hydrauliques proportionnelles avec la possibilité de réglage de la vitesse de tous les mouvements, aussi bien du sol que de la nacelle.
- Déport proportionnel à la charge dans le panier.
- Parallélogramme hydraulique de maintien à niveau nacelle.
- Sortie hydraulique des deux éléments télescopiques du bras.
- Chemins de câbles internes au bras.
- Clapets de blocage sur tous les mouvements.
- Pompe manuelle pour manoeuvre d'urgence.
- Arrêt coup de poing en cas de panne.
- Démarrage et arrêt du moteur du véhicule depuis la nacelle.
- Dispositif interdiction sortie télescopique à repos.



- Proportional electro-hydraulic controls from both control posts.
- Outreach proportional to cage load
- Hydraulic cage levelling.
- Synchronous multi-stage telescope cylinders.
- Internal hose and cable ducts.
- Hydraulic check valves on all movements.
- Emergency hand pump.
- Emergency stop on both control stations.
- Engine start-stop on both control stations.
- Telescope retainer in transport position.



- Elektro-Hydraulische Proportionalsteuerung mit Geschwindigkeitsregelung für alle Funktionen, von Korb- und Bodenbedienung.
- Stufenlose seitliche Reichweite, Korblast abhängig.
- Hydraulische Korbnivellierung.
- Synchron-ausfahrende Mehrstufen Teleskop-Zylinder.
- Innenliegende Kabel- und Schlauchverlegung.
- Hydraulische Sperrventile auf jede Bewegung.
- Not-Handpumpe.
- Not-Stop an beide Steuerpulte.
- Fahrzeug Start-Stop an beide Steuerpulte.
- Teleskopausfahrsperrung in Transportstellung.



- Comando elettroidraulico proporzionale con regolazione della velocità di tutti i movimenti sia dal cestello che da terra.
- Sbraccio proporzionale al carico sul cestello.
- Parallelismo idrostatico del cestello.
- Uscita oleodinamica degli sfili telescopici del braccio.
- Tubi e cavi installati all'interno del braccio.
- Valvole di blocco su ogni movimento.
- Pompa a mano di emergenza.
- Pulsante di arresto in caso di avaria.
- Avviamento e arresto del motore dell'autocarro dal cestello.
- Dispositivo di interdizione uscita telescopico con braccio a riposo.

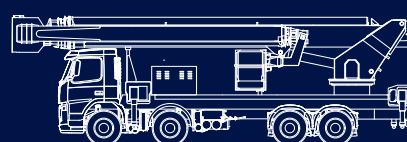
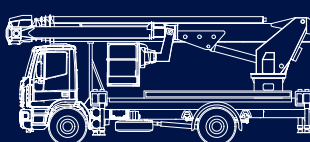
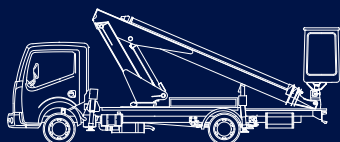



Subject to change without notice - Technische Änderungen vorbehalten!

# 160ALU

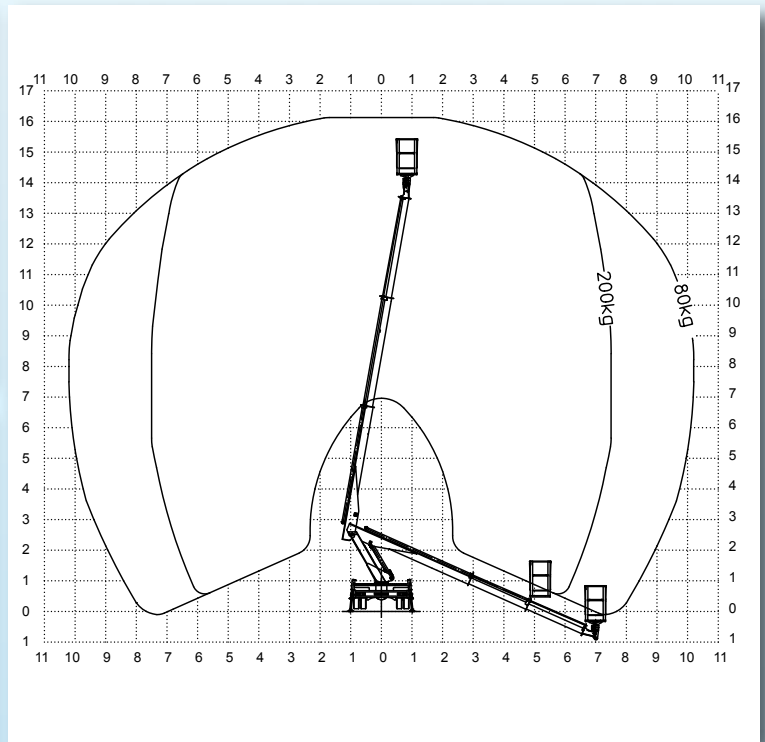
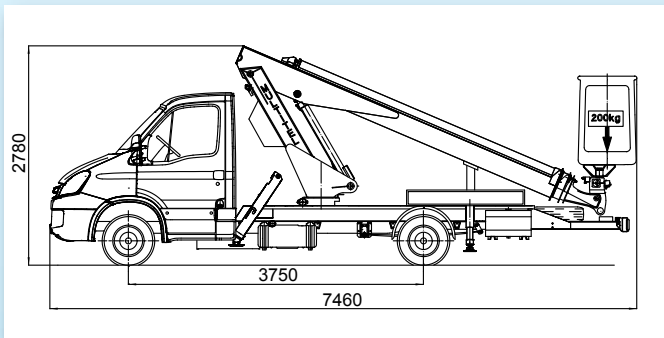
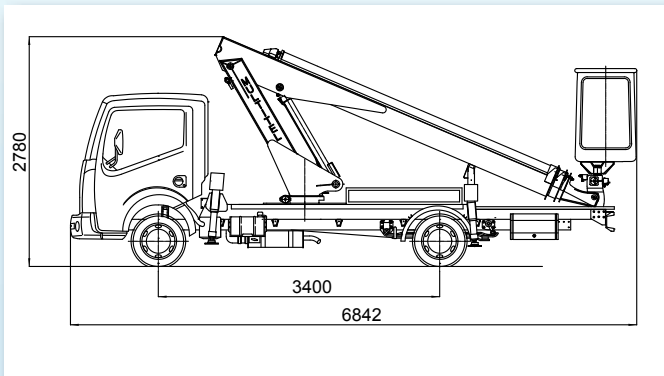

Hauteur de travail env.	Max working height	Maximale Arbeitshöhe	Altezza max di lavoro	<b>16,30 m</b>
Hauteur plancher nacelle env.	Maximum platform height	Maximale Plattformhöhe	Altezza piano calpestio cestello	<b>14,30 m</b>
Déport maxi de travail env.	Max working outreach	Maximale seitliche Reichweite	Sbraccio max di lavoro	<b>7,50 m (200 kg)-10,20 m (80 kg)</b>
Rotation de la tourelle	Turret rotation	Schwenkbereich	Rotazione torretta	<b>360°</b>
Rotation de la nacelle	Cage rotation	Hydraulische Korbdrehung	Rotazione idraulica del cestello	<b>60° + 60°</b>
Sortie télescopique des bras env.	Boom telescopic amplitude	Teleskopausschub	Escursione telescopica dei bracci	<b>6,82 m</b>
Dimensions maxi nacelle	Max cage dimensions	Max Arbeitskorbabmessungen	Dimensioni max del cestello	<b>1,60 x 0,70 x 1,10 m</b>
Charge utile en nacelle	Safe working load on cage	Tragfähigkeit	Portata cestello	<b>200 kg</b>
Dévers maxi admissible	Max admissible slope	Maximale zulässige Neigung	Pendenza ammissibile	<b>1°</b>

Et. 02/2017 Sous réserve de modification - Soggetto a modifiche senza preavviso

## MULTITEL



**DORN**  
ARBEITSBÜHNEN



DORN LIFT GMBH • Unterer Schützenweg 2, A-6923 Lauterach, Telefon 05574/736 88, Fax 05574/736 88 99, www.dornlift.com, office@dornlift.com

UID-ATU 38909400, LG Feldkirch, FN 133560m